

Reg. No. :

| | | | | | | | | | | | | | | | | | | | |
|--|--|--|--|--|--|--|--|--|--|--|--|--|--|--|--|--|--|--|--|
| | | | | | | | | | | | | | | | | | | | |
|--|--|--|--|--|--|--|--|--|--|--|--|--|--|--|--|--|--|--|--|

Question Paper Code : 25083

B.E./B.Tech. DEGREE EXAMINATION, NOVEMBER/DECEMBER 2018.

Third Semester

Electrical and Electronics Engineering

EE 8301 — ELECTRICAL MACHINES — I

(Regulations 2017)

Time : Three hours

Maximum : 100 marks

Answer ALL questions.

PART A — (10 × 2 = 20 marks)

1. Define fringing.
2. What is the important property of deltamax cores?
3. What is the condition for maximum efficiency of transformer?
4. Define voltage regulation.
5. State the principle of conservation of energy.
6. Give examples for continuous energy conversion equipment and force producing devices.
7. Why load voltage across DC shunt generator is decreasing with increase in load current?
8. What are the methods to improve commutation?
9. Why series motor should not started at no-load?
10. Which method is preferred for controlling the speed of DC shunt motor above the rated speed? Justify.

PART B — (5 × 13 = 65 marks)

11. (a) A ring has a diameter of 24 cm and a cross sectional area of 1000 mm². The ring is made up of semicircular sections of cast iron and cast steel with each joint having a reluctance equal to an air-gap of 0.2 mm. Find the ampere turns required to produce a flux of 8×10^{-4} Wb. The relative Permeability of cast-steel and cast-iron are 900 and 170 respectively. Neglect fringing and leakage effects. (13)

Or

- (b) A square-wave voltage of amplitude $E = 100$ V and frequency 60 Hz is applied on a coil wound on a closed iron core. The coil has 500 turns, and the cross-sectional area of the of the core is 0.001 m², Assume that the coil has no resistance.
- (i) Find the maximum value of the flux and sketch the waveforms of voltage and flux as a function of time. (6)
- (ii) Find the maximum value of E if the maximum flux density is not to exceed 1.2 tesla. (7)
12. (a) A single phase transformer has $Z_1 = 1.4 + j5.2 \Omega$ and $Z_2 = 0.0117 + j0.0465 \Omega$. The input voltage is 6600 V and the turn ratio is 10.6 : 1. The secondary feeds a load which draws 300 A at 0.8 power factor lagging. Find the secondary terminal voltage and the kW output. Neglect no-load current. (10 + 3)

Or

- (b) A 50 kVA, 2400 = 240 V transformer has a core loss $P_c = 200$ W at rated voltage and a copper loss $P_{cu} = 500$ W at full load. It has the following load cycle : (13)

| %Load | 0.0% | 50% | 75% | 100% | 110% |
|--------------|------|-----|---------|---------|------|
| Power factor | — | 1 | 0.8 lag | 0.9 lag | 1 |
| Hours | 6 | 6 | 6 | 3 | 3 |

Determine the all-day efficiency of the transformer.

13. (a) The magnetic system shown in Figure 1 has the following parameters : (13)

$$N = 500$$

$$i = 2 \text{ A}$$

$$\text{Width of air gap} = 2.0 \text{ cm}$$

$$\text{Depth of air gap} = 2.0 \text{ cm}$$

$$\text{Length of air gap} = 1 \text{ mm}$$

Neglect the reluctance of the core, the leakage flux, and the fringing flux.

- (i) Determine the force of attraction between both sides of the air gap. (6)
- (ii) Determine the energy stored in the air gap. (7)

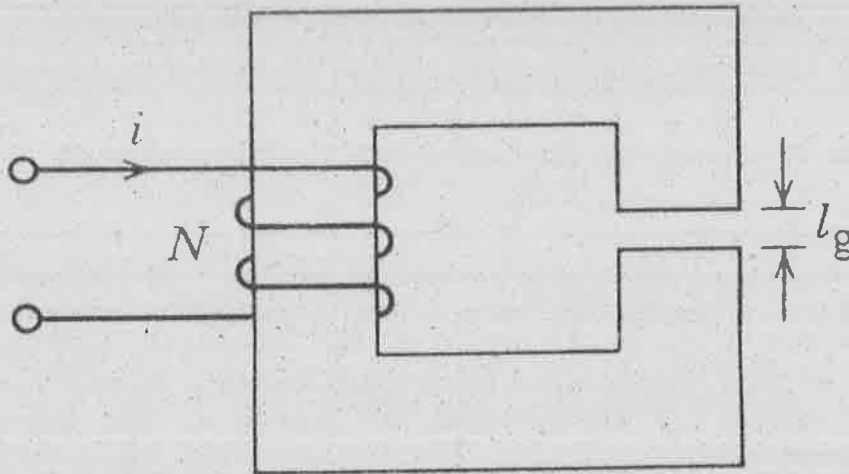

Figure. 1
Or

- (b) Derive the field energy, co-energy and force for a doubly excited systems. (5 + 5 + 3)
14. (a) A 4 pole DC shunt generator, with a shunt field resistance of 100 ohms and an armature resistance of 1 ohm, has 378 wave connected conductors in its armature. The flux per pole is 0.02 Wb. If a load resistance of 10 Ω is connected across the armature terminals and the generator is driven at 1000 rpm. Calculate power absorbed by the load. (13)

Or

- (b) A separately excited DC generator, when running at 1200 rpm supplies 200 A at 125 V to a circuit of constant resistance. What will be the current when the speed is dropped to 1000 rpm and the field current is reduced to 80 %. Armature resistance = 0.4 Ω and total drop at brushes = 2 V. Ignore saturation and armature reaction. (13)
15. (a) A 230 V DC shunt motor has an armature circuit resistance of 0.4 Ω and field resistance of 115 Ω . The motor drives a constant torque load and takes an armature current of 20 A at 800 rpm. If motor speed is to be raised from 800 to 1000 rpm, find the resistance that must be inserted in the shunt field circuit. (13)

Or

- (b) Explain the various characteristics of DC compound motor with necessary graphs. (13)

PART C — (1 × 15 = 15 marks)

16. (a) A transformer with normal voltage impressed has a flux density of 1.2 T and core loss comprising 1200 W eddy current loss and 3500 W hysteresis loss. What do these losses become under the following conditions :
- (i) Increasing the applied voltage by 5% at rated frequency; (5)
 - (ii) Reducing the frequency by 5% with normal voltage impressed; and (5)
 - (iii) Increasing both impressed voltage and frequency by 5%. (5)

Or

- (b) A series generator having a combined armature and field resistance of 0.4Ω is running at 1000 rpm and delivering 5.5 kW at a terminal voltage of 110 V. If the speed is raised to 1500 rpm and the load adjusted to 10 kW, find the new current and terminal voltage. Assume the machine is working on the straight line portion of the magnetization characteristics. (15)